



**emotoare**

800/3

**Three phase-2poles-3000RPM-50HZ  
230/400 Voltage**

Mechanical Features			Electric Features		
<b>General</b>			<b>General</b>		
Working moment	<b>15.68</b>	kg.cm	Nominal voltage	<b>Δ:230V</b>	<b>Y:400V</b>
Unbalance	<b>7.84</b>	kg.cm	Input power	<b>0.75KW</b>	
Force	<b>794</b>	kg	Current A max	<b>Δ:2.52A</b>	<b>Y:1.45A</b>
<b>Bearing</b>			Power factor	<b>0.79</b>	
TYPE(C&U)	<b>6306</b>		La/in	3.8	
	100%	<b>1056</b>	<b>Certification</b>		
Life(h)	80%	<b>2044</b>	ETL CLASS II DIV.II	<b>T4</b>	
	50%	<b>8269</b>	GROUP F G TENV NEMA 4		
<b>Bearing Grease</b>			ATEX II 3D Ex tD A22	<b>T135°</b>	
Lube Schedule			IP66		
Lube replacement			Amb Temp. <b>(-20°~+40°)</b>		
Grease Type					

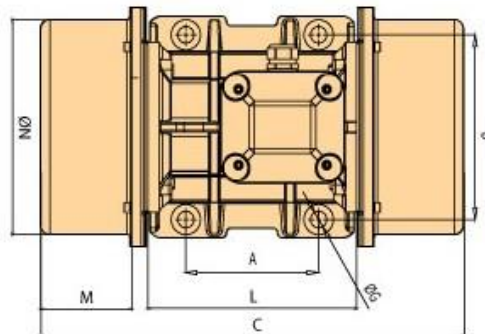
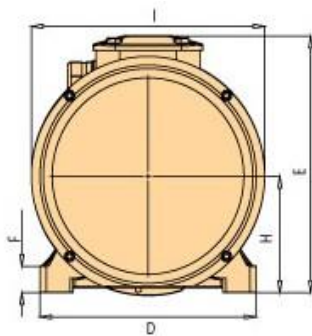

A	120
B	170
C	321
M	58
G	17
Holes	4
D	208
E	210
F	22
H	94
I	180
L	205
N	170

Clamping torque(Nm) **185**

n.weight	Screw	washer	Cable type	Cable Glande
21.8	M16	17X30	4GX2.5	M20X1.5